

Toyota 1KS + Polar 8000 Series Alternators



PROPANE | BUTANE | NATURAL GAS | LPG | CNG | LNG

- High Performance and Low Fuel Consumption
- 60,000-90,000 Hour Engine Service Life
- Easy Maintenance

Model 1KS-GEN

- 3.8-liter oil sump
- 500-hour oil change
- 60-Amp SLI Alternator



Model 1KS-GEN

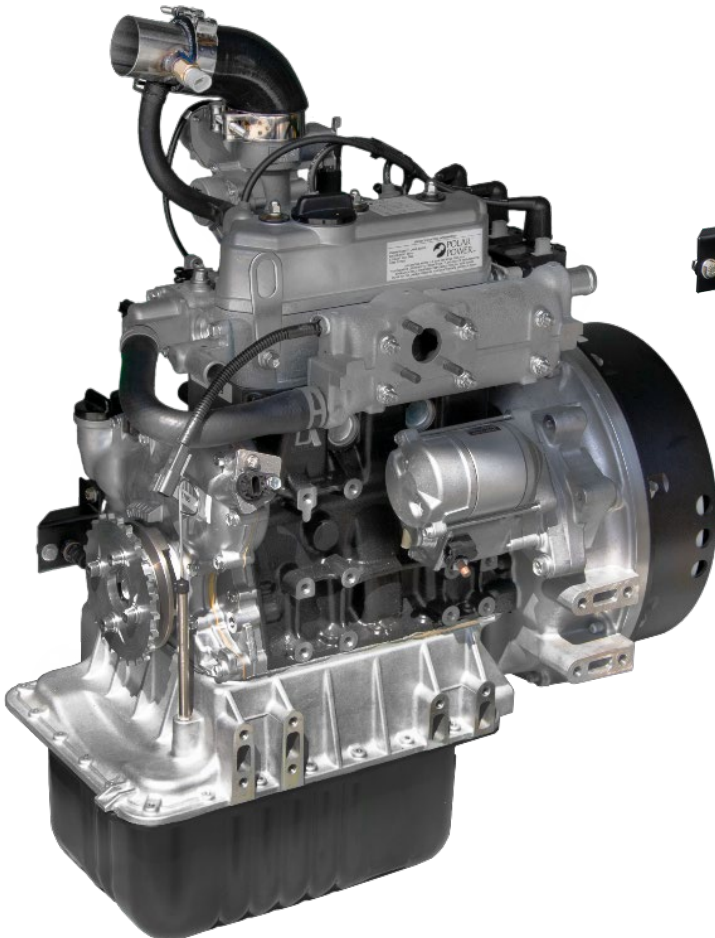

Model 1KS-CHP

Model 1KS-CHP

- 15-liter oil sump
- 4,500-hour oil change
- No SLI alternator
- No belts or pulleys
- Off engine electric coolant pump

Toyota 1KS-GEN vs 1KS-CHP

Selection Criteria - The number of operating hours per year is key factor in choosing between the 1KS-GEN and 1KS-CHP engine models. The 1KS-CHP it is the preferred choice when it comes to 24/7 operation and where availability of service is limited due to the remoteness of the installation, technician shortages, or adverse weather conditions limiting site access.

Maintenance Requirements - The 1KS-CHP has a 15-liter oil sump providing 4,500-hour oil change intervals. The 1KS-CHP eliminated the V-belts and engine mounted coolant pump further reducing maintenance and repair. The 1KS-GEN has a 3.8-liter oil sump with 500-hour oil change, but the V-belts and engine mounted coolant pump are present. Both the 1KS-GEN and 1KS-CHP engines require fully synthetic oil for their long service life. If the annual run times are considerably less than 4,500 hours, then the 1KS-GEN may be the better choice as the engine cost is lower and less oil will be used annually.

Difference between Toyota and other LPG / Natural Gas Engines

Clear Advantage - The Toyota 1KS engine series generates more power and higher fuel efficiency than other gas engines because of its 12:1 compression ratio which can take advantage of the high-octane ratings provided by natural gas, propane, and butane fuels.

Categories	Conventional	1KS-CHP	1KS-GEN
Fans Power Consumption	750-1,500 W	50-500 W	50-500 W
Coolant Pump	900-1500 W	100-160 W	900-1500 W
SLI Alternator	200-1,300	No Alternator	200-1,300
V-Belt Loss	7% loss	No V-Belt	7% loss
Starting Battery	Lead acid	Super-capacitor	Super-capacitor
Oil Sump Capacity	2-3 liters	15 liters	3.8 liters
Oil Change Frequency	200 hrs	4,500 hrs	500 hrs
Compression Ratio	8:1 – 10:1	12:1	12:1

Compression Ratio - Most engines converted from gasoline to natural gas and LPG have compression ratios of only 8:1 to 10:1 due to gasoline's lower octane rating. The 1KS engines are produced from diesel engine blocks that use compression ratios of up to 20:1 and can easily accommodate the 12:1 compression, and provide 60,000 to 90,000 hours of reliable service life.

Combustion Efficiency - The engine's pistons are also engineered for higher pressure and provide combustion efficiency while minimizing oil consumption. Specially designed spark plugs for the 1KS-CHP provide up to 10,000 hours of run service, reducing trips needed to maintain engines in remote locations.

Engine Control Unit (ECU) - Polar engineers have combined the Toyota 1KS engines with Bosch ECU providing optimum real-time control of the air/fuel mixture ratio (lambda) to reduce exhaust emissions and improve fuel efficiency. An O2 sensor on the exhaust closes the lambda control loop. The ECU also manages engine speed and regulates engine cooling.

Increased engine fuel efficiency

Removing parasitic engine loads from the engine improves fuel efficiency while increasing reliability:

Radiator Fans - Electric radiator fans are used on both the 1KS GEN and CHP engines. Depending on the engine RPM the belt driven fan can consume 1 Hp to 2 Hp of the engine's power on conventional generators. Variable speed electric fans consume less power at 0.06 Hp to .8 Hp (50 to 600 watts) depending on ambient temperature. Removing the belt driven fan also reduces noise and facilitates various packaging options by letting the radiators to be installed at different locations.

Coolant Pump -The electric coolant pump used on the 1KS-CHP draws 100 to 160 watts. The belt driven coolant pump on the 1KS-GEN (and other generators in this size range) consumes 900 to 1,500 watts (1.2 Hp to 2 Hp).

Belts and Alternator - The 12 Vdc SLI belt driven alternator (for ignition and control) on the 1KS-GEN draws between 200 to 1,300 watts depending on the alternator electrical load. The 1KS-CHP draws its 12 Vdc power from a power supply operating off the main alternator. V-Belts losses are about 7% when driving the coolant pump, SLI Alternator, and Fan. Removing the belt saves energy and removes a common cause for engine failure.

ECU - Controlling the air / fuel mixture near stoichiometric increases fuel economy. The ECU controls the air / fuel mixture valve in the carburetor.

Toyota's 1KS Engines reduce Maintenance and increase Reliability

Starting Battery - Polar's generator replaces the starting battery with a supercapacitor providing higher starting reliability in all weather conditions over a 10-to-15-year life.

Coolant Pump - The 1KS-CHP belt driven coolant pump and radiator cooling fan are replaced with an energy efficient electric fan and electric coolant pump. The coolant pump without seals and driven with a brushless DC motor provides years of long life and ease of replacement.

Oil Sump Capacity - Oil is a critical maintenance item and having a 15-liter oil sump capacity in 1KS-CHP increases the likelihood of having good oil for the engine all the time. Having small oil capacity and frequent oil changes increases the chance of not being able to change oil when needed.

Ease of Maintenance - Increase engine maintenance intervals up to 1 year compared to 2 to 4 weeks for traditional low duty cycle LPG engines.

Rugged Engine Design - Cast iron engine block with 4 large crankshaft bearings (between each cylinder). Stellite valves to meet the higher combustion temperatures of LPG and Natural Gas.

No internal timing belts or chains - Instead the overhead valves are gear driven, providing years of reliable service.



Model 1KS-GEN

Polar Power's alternator and controls provide proven Reliability and Efficiency

Permanent Magnet - Polar Power's DC generators combine the reliability of Toyota engines with the 8000 series alternators with Supra system controls. The 8000 series is a 32-pole permanent magnet, pancake style alternator optimally engineered for DC outputs. Tens of thousands of alternators are operating in all weather extremes for over 20 years, clearly proven reliability of our designs and technology. Over 100,000-hour operational field life, attributable to:

No Bearings - The rotor is very short and bolts directly to the engine's flywheel. This arrangement eliminates the need for bearings and their required maintenance.

No Brushes or Slip Rings - The brushless design of a PM alternator offers higher reliability by eliminating exciters.

No ATS - The DC generator design eliminates the need for Automatic Transfer Switches.

No High Temperatures - Low temperature rise inside the alternator.

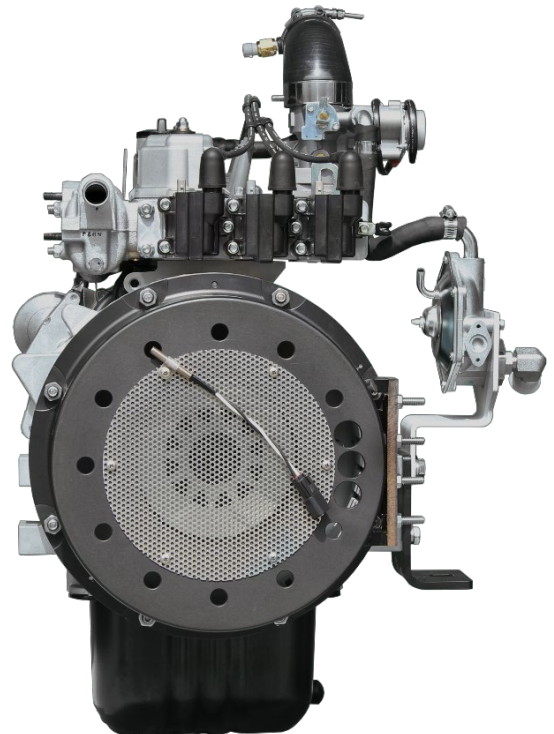

Model 1KS-CHP

Specifications

Engine Model	Toyota 1KS	
	GEN Option	CHP Option
Cylinder Arrangement	Inline Type 3-Cylinder	
Total Displacement	952 cc	
Bore x Stroke	72 x 78 mm	
Valve Type	OHV Gear Drive	
Combustion Chamber Design	Heron Type	
Compression Ratio	12:1	
Fuel Control	Electronic Throttle Body	
After Treatment	Catalyst for LPG	
Configuration	4-Cycle Liquid Cooled System	
Max. Output kW/rpm (Reference Value) Flywheel Mechanical	14.7Hp / 1,500rpm 18.6Hp / 1,800rpm 28.2Hp / 3,000rpm	
Max. Torque Nm/rpm (Reference Value)	-	72Nm / 2,400rpm
Specific Fuel Consumption at Rated Speed (Reference Value)	-	207 g/kWh
Dimensions (Length x Width x Height)	581 x 630 x 560mm	588 x 531 x 689mm
Dry Weight Approximation	110kg	102kg
ECU	Bosch	
Electric Power Output	5-15kW	
Generator Voltage Output	24-750VDC	

Dimensions

1KS-GEN with Polar 8340 Alternator

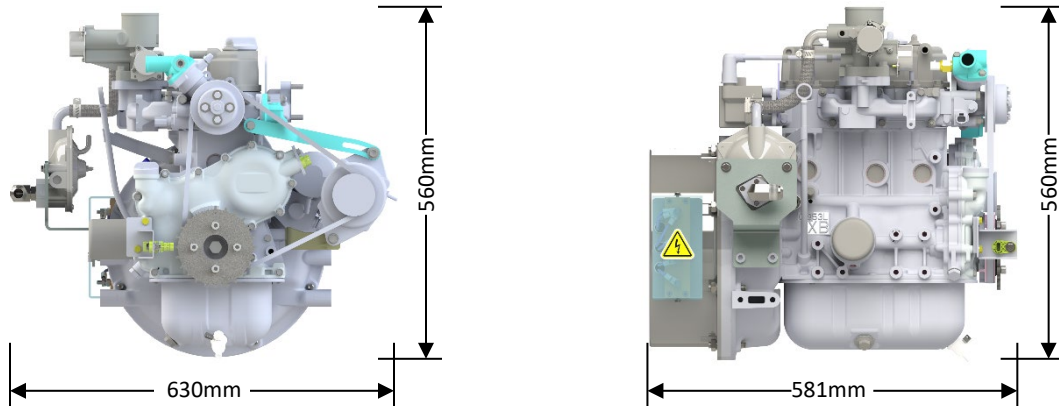

1KS-CHP with Polar 8340 Alternator

