

Open Frame

for Polar DC Generators

Open frame generator set option

The open frame is designed for installation within a walk-in shelter.

A walk-in shelter is the preferred set-up for our customers as it facilitates easy generator maintenance. We find higher-quality services can be given to the generator when the mechanic can walk into the enclosure, close the door behind him, turn on the light and work on the generator without snow, wind, or rain pouring affecting him.

A closed enclosure within a shelter tends to reduce preventative maintenance, as any component that's hidden from sight is also hidden from mind.

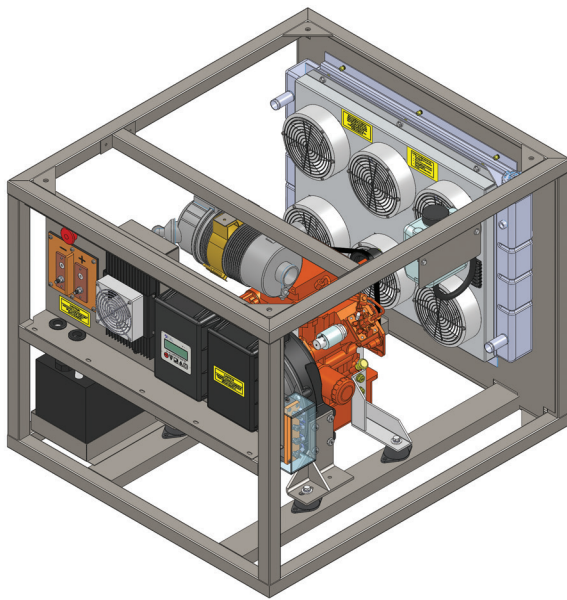

Being able to see all the components without removing any panels facilitates preventative maintenance by making it easy to observe any components exhibiting a problem, for example a leak.

We have two standard frame sizes:
4 to 10 kW and 10 to 20 kW.

Features

The open frame is designed to be pushed against the wall with the shelter wall and has a cut-out allowing the radiator to blow the hot air directly to the outside.

You may remove the radiator from the open enclosure in place the radiator on the outside of the shelter, thereby reducing the amount of air is required to circulate through the shelter. This is advantageous in arctic type climates because the large volume of cold air drawn in by the radiator can cause other appliances to freeze. Placing the radiator on the outside of the shelter allows only the air required for engine combustion to enter the shelter and the larger volume of air required for radiator cooling is left outside the shelter. The requirements for placing the radiator outside the shelter in arctic environment do require more instruction than described on this page, please consult with Polar Power.

The open frame allows for stacking of the generators, one on top of another.

The open frame is constructed of 1.5 inch steel square tubing.

Dimensions

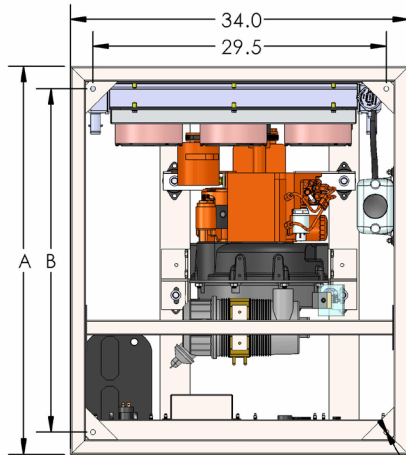

8 X Ø.5
(4 TOP, 4 BOTTOM)

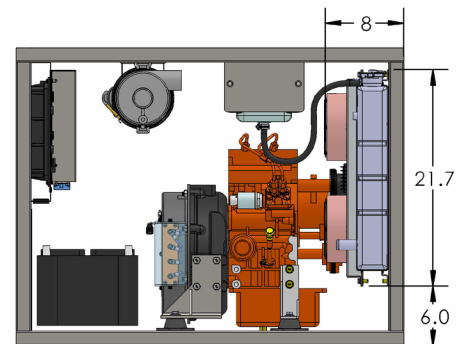
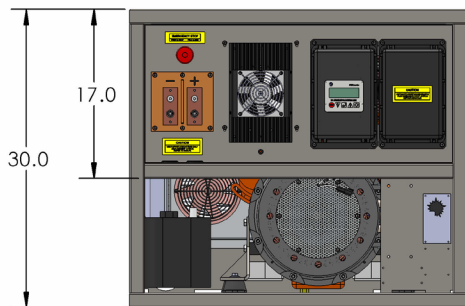
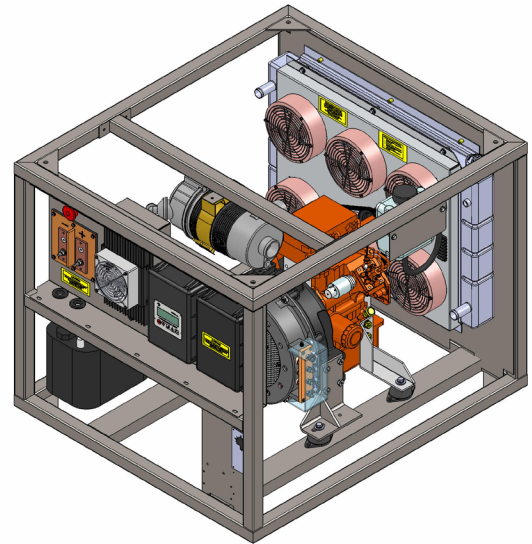

Part Number	Description	A	B	Weight
88-25-200	4 to 10 kW	39"	34"	75 lb
88-25-201	10 to 20 kW	46"	41"	83 lb

To determine total Generator weight add:

Aluminum Radiator 19 lb

Fan tray 19 lb

Controls and wire harness 22 lb

And the selected engine

Electric Radiator

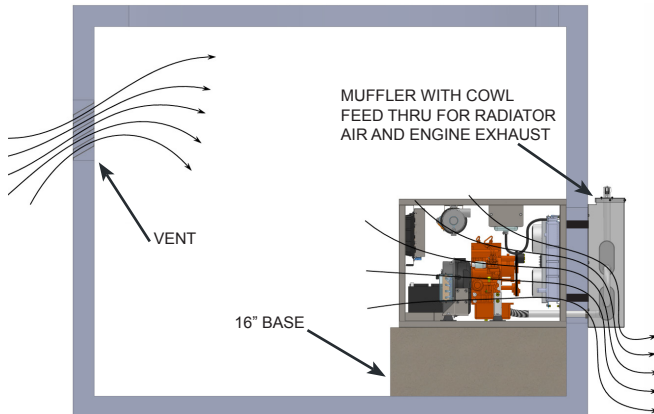

This installation configuration has the electric radiator mounted within the open frame assembly. Air is drawn into the shelter through louver in the shelter wall by the electric fans on the radiator. The electric fan pushes the cooling air through the radiator and exits the shelter directly. The volume of air moving through the air intake louver on the shelter wall has to satisfy both requirements of combustion air and radiator cooling. To simplify thermal insulation of the silencer /muffler and improve space inside the shelter the silencer is mounted external to the shelter. This is the most popular installation configuration as it keeps the generator and its fluids as one assembly within a frame.

Vent air requirements for cooling and combustion is a nominal:

- 1200 cfm - 6 kW and smaller
- 1500 cfm - 10 kW and smaller
- 1800 cfm - 17 kW and smaller

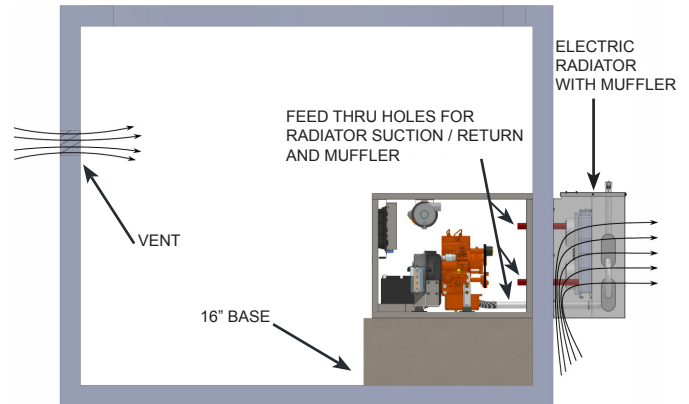

This installation configuration has the electric radiator and silencer / muffler assembly external to the shelter. This installation has popularity in very cold climates where there is the need to reduce the amount of low temperature air moving through the shelter. In this configuration only the combustion air and a very small amount cooling air is required from the vent on the wall.

Vent air requirements for cooling and combustion is a nominal:

- 300 cfm - 6 kW and smaller
- 450 cfm - 10 kW and smaller
- 600 cfm - 17 kW and smaller